

TECHNICAL SPECIFICATION SHEET

UNI-FLO

VERTICAL GAS/LIQUID SEPARATORS

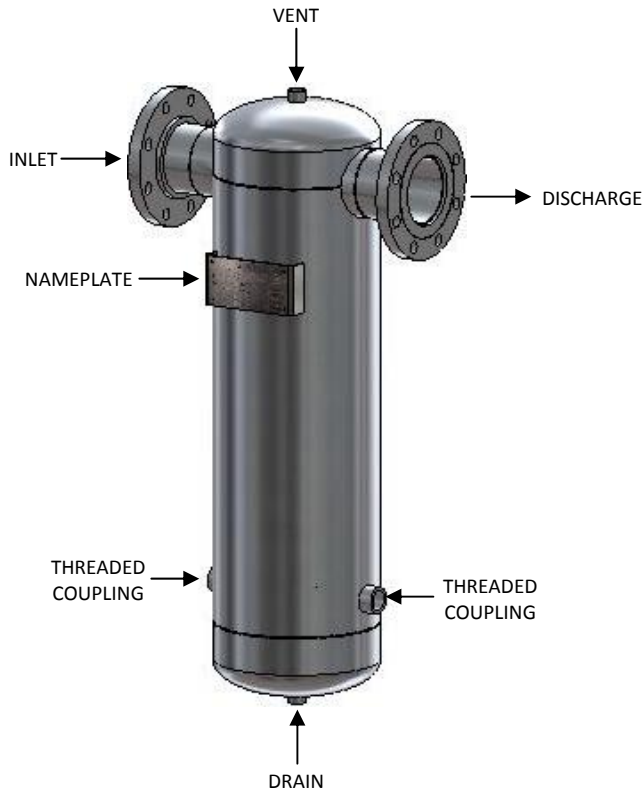

FEATURES

- MULTIPLE SIZES AVAILABLE TO MATCH YOUR SPECIFICATIONS
- 304L STAINLESS STEEL CONSTRUCTION
- VESSELS ARE DESIGNED PER ASME SECTION VIII, DIV. 1
- NO MAINTENANCE REQUIRED
- EXCELS IN HIGH LIQUID LOAD APPLICATIONS

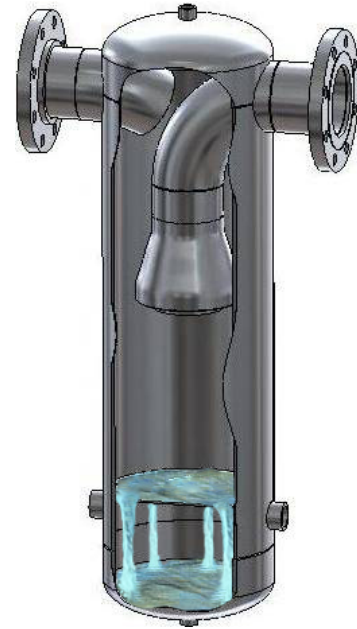

OPTIONS

- CAN BE CUSTOM BUILT TO FIT ANY APPLICATION
- 316L STAINLESS STEEL CONSTRUCTION
- ASME SECTION VIII, DIV. 1 STAMPED
- HIGH LIQUID LEVEL SWITCH
- FLOAT OPERATED DRAIN

DIMENSIONS AND WEIGHTS

PIPE SIZE A	FLANGED B	DIA. C	NPT DRAIN STD	LIQUID CAPACITY (GALLON)
1-1/2"	11-1/2"	4"	1/2"	0.5
2"	11-1/2"	6"	1/2"	1.0
3"	18"	8"	1/2"	1.75
4"	20"	10"	1/2"	2.75

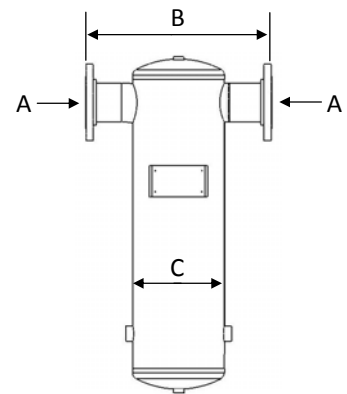

UNISON SOLUTIONS, INC. OFFERS A WIDE VARIETY OF HIGH QUALITY STAINLESS STEEL COMPONENTS DESIGNED TO SUPPORT THE AIR AND GAS INDUSTRY.